

**MAXI**FLOOR

## Installation Guide



BR-006, May 2018 - MaxiFloor  
Low-Rise Multi-Residential  
Buildings & Houses

**BigRiver**

Building Australia for over 100 years

**MAXI**FLOOR





## 1.0 About Big River

Big River Group began in the early 1900s as a family owned timber business. Today, it has advanced and established itself as a major Australian building materials distributor, supplying an extensive range of high quality timber, builder's hardware, building supplies and services for the residential, commercial, industrial, building and construction industries.

Big River distributes the MaxiFloor and MaxiFloor AAC panels exclusively in Australia. Its distribution outlets are strategically located throughout the country with Perth, Melbourne, Sydney, Illawarra, Canberra, Brisbane, Gold Coast, Sunshine Coast, Townsville and Adelaide offering customers national coverage with local delivery.

## 2.0 Contents & Use of Manual

<b>MaxiFloor Panel</b>	<b>4</b>
<b>Advantage &amp; Benefit</b>	<b>5</b>
<b>Design Consideration</b>	<b>6</b>
<b>System Component</b>	<b>7</b>
<b>Construction Notes</b>	<b>8</b>
<b>Fixing Specification</b>	<b>10</b>
<b>Installation Detail</b>	<b>11</b>
<b>System Properties</b>	<b>17</b>
<b>Material Handling</b>	<b>19</b>
<b>Material Property</b>	<b>20</b>
<b>Standard &amp; Compliance</b>	<b>20</b>
<b>Responsibility &amp; Warranty</b>	<b>21</b>

This Installation Guide contains design and installation details intended for use as a general guide by qualified design and building construction professionals including licensed builders in the construction of external walls for low-rise multi-residential buildings and houses.

It does not substitute the essential evaluations, assessments and decisions of qualified design and building construction professionals. They should be consulted to ensure that the specific wall systems, its components and installations are suitable for the projects and conform to the National Construction Code of Australia (NCC).

Big River is not responsible for ensuring the correctness or suitability of the installation details and systems or its compliance with federal, state or local laws and regulations, including building, environmental and other codes.

### 3.0 MaxiFloor Panel

MaxiFloor panel is an autoclaved aerated concrete (AAC) steel reinforced, durable, lightweight panel that offers excellent benefits for flooring applications in houses, low-rise multi-residential and light commercial buildings.

The MaxiFloor panels come in thickness of 50mm and 75mm and are installed directly over timber or steel framing floor joist systems. The MaxiFloor system has a number of distinct advantages over traditional flooring systems such as particleboard and concrete floors. It is lightweight, strong and solid and has superior sound and thermal characteristics inherent to AAC and exceptional fire resistance level.

Made from natural raw materials - lime, sand, gypsum, water and a small amount of aerating agent plus cement, the MaxiFloor panel is ecologically friendly and energy conserving. It is faster to install, easy to handle and offers flexible solutions as base material for carpet, tiles, floorboards and timber flooring. MaxiFloor panels can also be used for decks and balconies.

AAC has been used in Europe for more than 70 years and is widely accepted in Australia since its introduction over 25 years ago as a lightweight material for flooring, cladding, fencing and sound barrier walls.

MaxiFloor panels are available in the following dimensions and steel reinforcement.



- Thickness:** 50mm, 75mm
- Width:** 600mm
- Length:** 1800mm (75mm thick),  
2200mm (50mm thick)
- Reinforcement:** Single steel mesh, centrally located
- Steel wire:** 4 x 5mm longitudinal and  
6-8 transverse bars

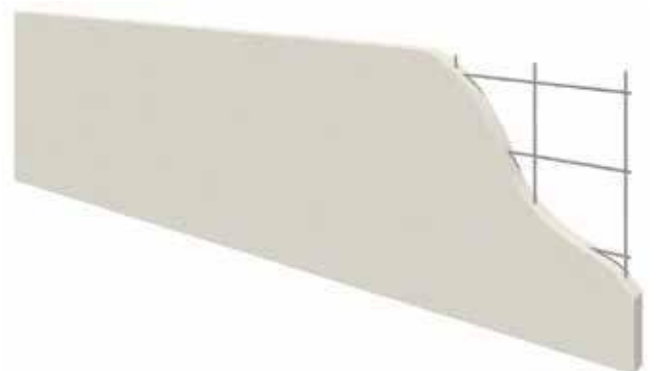

## 4.0 Advantage & Benefit



### **Environmentally Friendly and Sustainable**

Helps reduce about 30% of environmental waste compared to traditional concrete and 50% of greenhouse gas emissions.

---



### **Energy Cost Savings**

Excellent insulation properties with improved thermal efficiency that reduces the heating and cooling load in buildings.

---



### **Excellent Soundproofing**

Effective sound barrier for privacy both from outside noises and other rooms when used as interior partition walls.

---



### **Superior Fire Protection**

Non-combustible. Suited for fire-rated applications achieving a two hour rating when installed with approved systems.

---



### **Non-toxic Substances**

Pollutant free building material that does not emit toxic gases or other toxic substances.

---



### **Quick Construction**

Easy to work with, including cutting, shaving and shaping thus reducing construction time and labour costs.

---



### **Lightweight and Durable**

Durable and dimensionally stable, the lightweight cellular properties provide design and construction flexibility.



## 5.0 Design Consideration

For the MaxiFloor system to be effective and economical the following design process to capitalise on the product benefits and architectural features is important.

- Determine supporting structures – joists, bearers, beams, columns and support walls are designed to resist permanent action of the MaxiFloor panels with relevant superimposed permanent, imposed and other actions as appropriate for the application.
- Ensure the floor system complies with the requirements of the NCC (National Construction Code).
  - › Fire Resistance Level (FRL)
  - › Bushfire Attack Level (BAL)
  - › Sound Insulation Performance (Rw values)
  - › Energy Efficiency (R-Value)
- Determine load capacity, frame quantity and spacing, screw fixing and bearing support (refer to Table 2 and Table 3 – Load Capacity & Span).
- Framing joists must comply with AS 1684 for timber frames and NASH standard for residential and low-rise steel frames.
- Fasteners must comply with AS 3566
  - Class 3 coated screws are to be used in a benign or moderate environment.→ Class 4 coated screws are to be used for marine exposure of more than 100m from breaking surf.

→ Grade 304 or 316 stainless steel screws to be used for severe marine exposure less than 100m from breaking surf.





- Select insulation and/or other floor elements to meet energy efficiency requirements.
- Flashings and damp-proof courses must comply with AS 2904 and installed in accordance with NCC requirements.
- Exposed floor areas must be fully sealed with waterproof tanking membrane to all exposed AAC surfaces prior to installation of selected floor coverings.

The MaxiFloor system for low-rise multiresidential buildings and houses in this guide is based on accepted design principles used in a typical Australian residential building to satisfy the nominated performance requirements of the NCC, Volume One, Building Code of Australia (BCA) for Class 2 to Class 9 Buildings and Volume 2 – Class 1 and Class 10 Buildings – Housing Provisions.

It is important that a Designer and/or Project Engineer assess the adequacy of the floor system and approve construction design and compliance with NCC performance requirements.

The MaxiFloor panel comes with CodeMark™ Certificate of Conformity and/or compliance to the nominated performance requirements of AS 5146 and NCC, Deemed-to-Satisfy Provisions. Please refer to Big River Group for further information.

## 6.0 System Component

<b>The Bin Adhesive</b>	Factory prepared blend of carefully selected raw materials such as cement, graded aggregates and strengthening and performance additives. A dry mixed product used as a structural thin bed adhesive for adhering the panels in the construction of floors.
<b>Construction Adhesive</b>	Thin-bed mortar with high strength specifically manufactured for the placement of panels where levelling and bonding is required for floor construction. The mortar helps in the integrity of an airtight construction for sound insulation and fire protection at the base of the panels.
<b>Patching Compound</b>	Pre-mixed, water based jointing and patching compound used for repairing minor chips, cracks and damages particularly to the corners and edges of panels. It can also be used as a filler compound.
<b>Joint Sealant</b>	Sealing joints and floor penetrations that are subjected to high humidity and movements. The joint sealant provides superior integrity for fire and acoustic sealing. Even when excessively stretched, sealants help maintain the joint's integrity.
<b>Anti-corrosion Paint</b>	Coating and protection of the exposed steel reinforcement mesh from corrosion after cutting.
<b>No.14-10 x 75 mm Bugle Head Type 17 Screw 50mm Panel to Timber Joist</b>	
<b>No.14-10 x 75 mm Bugle Head Tek Screw 50mm Panel to Steel Joist</b>	
<b>No.14-10 x 100 mm MP Bugle Head Type 17 Screw 75mm Panel to Timber Joist</b>	
<b>No.14-10 x 95 mm Hex Head Tek Screw 75mm Panel to Steel Joist</b>	

**Important:** System components must be approved and/or supplied by Big River and its supply partners.  
Refer to [www.bigrivergroup.com.au](http://www.bigrivergroup.com.au)

## 7.0 Construction Notes

### 7.1 Framing and fixing

- Framing and fixing shall be in accordance with the required design considerations described in Section 5 and fixing specification in Section 8.
- Line loads and concentrated point loads shall have support pathway directly under the MaxiFloor panel. Design loads must not exceed the factored compressive strength capacity of the AAC.
- Structural bracing of wall frames and hold-down shall be carried through to the floor framing members.
- All framing joists shall be leveled and flat to provide even bearing for support of MaxiFloor panels.
- Panels should be installed spanning a minimum of 3 joists and continuously supported at free sides as follows:
  - a. Minimum 45 mm from end bearing.
  - b. Minimum 35 mm from edge bearing.
- Panel ends in the field of the floor shall be evenly supported on a joist with minimum 20 mm bearing. Screws are not required for this joint. Ensure construction adhesive bonds both panels to joist.
- Apply a continuous bead of construction adhesive (min. 5 mm wide) to every joist in accordance with the manufacturer's instructions. Provide 2 beads at locations of panel end joints in the field of the floor.
- Fix panels to joists with screws specified in Table 1. – Connection Specification and adhere to the following:
  - a. 2 screws per panel per joist except at panel ends in the field of floor.
  - b. Minimum end distance – 50 mm (angled as required).
  - c. Edge distance – 100 mm.
  - d. Patch screw heads in the panel's surface with thin bed AAC patching compound.
- Panels are to be laid out over the floor in a stretcher bond pattern. Minimum 450 mm overlap or single joist spacing, whichever is greater.
- Panels must be joined using approved AAC thin bed adhesive. Joints shall be 2- 3mm thick and fully filled with adhesive. Wipe off excess and fill gaps, if any.
- Provide light gauge steel angle trim (min. 30 x 30 x 1.0 mm) to the leading edge of floor at exposed edges, such as the top of stairs. MaxiFloor panel is not suitable for stair threads.
- Minimum panel width when trimmed shall be 250 mm.

### 7.2 Footings and Supporting Structures

- Footings supporting MaxiFloor shall be designed, specified and constructed in accordance with AS 2870. Due consideration should be given to the permanent load of the panels. Sub-floor spacing must be provided for adequate ventilation. Refer to NCC Volume Two Part 3.4.1 for nominated requirements.

### 7.3 Damp-Proof Courses

- Damp-proof courses must be installed below the floor framing to prevent moisture from rising damp.



#### 7.4 Control Joints

- To control cracking resulting from the expansion and contraction of the AAC, concrete slab, foundation movement and thermal expansion or contraction, control joints need to be installed.
- Provide control joints, minimum 10mm wide in floors at the following locations:
  - a. Max. 6,000 mm grid.
  - b. A change in floor thickness.
  - c. Corresponding to supporting structure steps or control joints.
  - d. Junctions of different floor system types.
  - e. Over structural beams supporting the floor framing members.

#### 7.5 Sealant and Backing Rod

- Seal control joints with backing rod and external grade polyurethane sealant, fire and/ or acoustic rated if required, min. 10 mm width and 5 mm deep.
- Sealant shall be approved for the application by the manufacturer. Surfaces to be bonded must be clean, free of dust and debris and prepared and primed as required.

#### 7.6 Waterproofing

- Waterproofing of the floors for wet areas must comply with the performance requirements in NCC Volume One 3.8.1.2 and AS 3740 using products suitable with AAC.
- External floors shall be waterproofed using membranes complying with AS 4654 Part 1 that are suitable with AAC and installed in accordance with AS 4654 Part 2.

- The MaxiFloor including framing members must be constructed above the DPC and exposed floor areas must be fully sealed with a waterproof tanking membrane to all exposed AAC surfaces prior to installation of tiling or other floor surface coverings. The tanking membrane shall not be penetrated by fixings.

#### 7.6 Penetrations

- Penetrations that are greater than 80 mm must be back blocked. Provide a 5-10 mm gap around the service to allow for differential movement between the panel and service. Any gap must be fully filled with approved flexible sealant and backing rod.
- Where required fire rated sealant and fire rated penetration collar may need to be installed around the service and penetration if fire resistance levels are specified. Consult a fire engineer for penetrations through floors to ensure compliance with NCC.
- Where multiple penetrations through the same panel are required, locate them in line and parallel to the long edge of the panel. If multiple penetrations reduce the panel strength additional structural support should be provided.

#### 7.7 Termite Management

- Although MaxiFloor panels are resistant to termites, protection from termite attack is a mandatory requirement for internal building components. It is the builder's responsibility to ensure that all laws imposed by the States and local councils are fully adhered to in the protection of buildings from termite attack in accordance with AS 3660.1.

## 8.0 Fixing Specification

The MaxiFloor panel can be fixed directly over structural timber or steel joist. Typically, joist shall be minimum 45 mm wide for timber and 50 mm wide for steel. Fixing will depend on the project design and engineer's specification.

**Table 1. Connection Specification**

Floor System	Frames	Fasteners
MaxiFloor 50	Panel to timber joist	No.14-10 x 75 mm Bugle Head Type 17 Screw
	Panel to steel joist	No.14-10 x 75 mm Bugle Head Tek Screw
MaxiFloor 75	Panel to timber joist	No.14-10 x 100 mm MP Bugle Head Type 17 Screw
	Panel to steel joist	No.14-10 x 95 mm Hex Head Tek Screw

### Fixing Detail

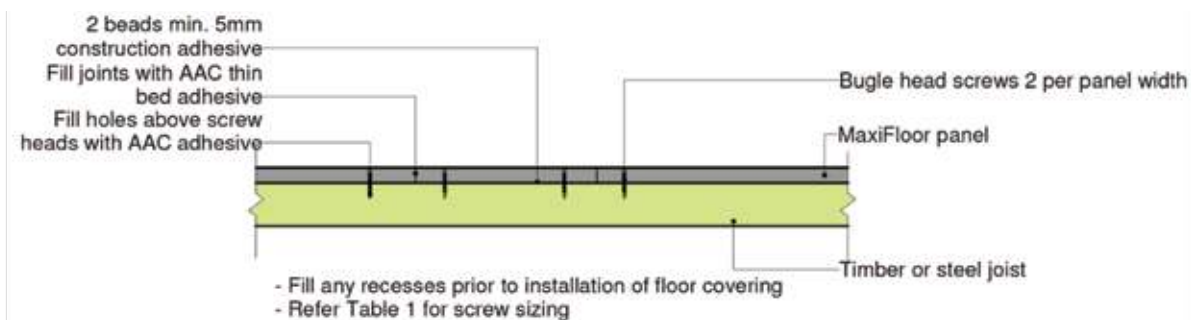

**Table 2. Load Capacity & Span - MaxiFloor 50**

Flooring Application	Distributed Imposed Action	Concentrated Imposed Action	Maximum Continuous Span
Residential – General Areas	1.5 kPa	1.8 kN (350 mm <sup>2</sup> )	450 mm
Residential – Tiled Areas	1.5 kPa	1.8 kN (350 mm <sup>2</sup> )	400 mm
Residential – Balconies and Verandahs	2.0 kPa	1.8 kN (350 mm <sup>2</sup> )	400 mm
Commercial	5.0 kPa	2.7 kN (0.01 mm <sup>2</sup> )	300 mm

**Table 3. Load Capacity & Span - MaxiFloor 75**

Flooring Application	Distributed Imposed Action	Concentrated Imposed Action	Maximum Continuous Span
Residential – General Areas	1.5 kPa	1.8 kN (350 mm <sup>2</sup> )	600 mm
Residential – Balconies and Verandahs	2.0 kPa	1.8 kN (350 mm <sup>2</sup> )	600 mm
Commercial	5.0 kPa	2.7 kN (0.01 mm <sup>2</sup> )	450 mm

## 9.0 Installation Detail

### 1. MaxiFloor AAC Panel With Carpet

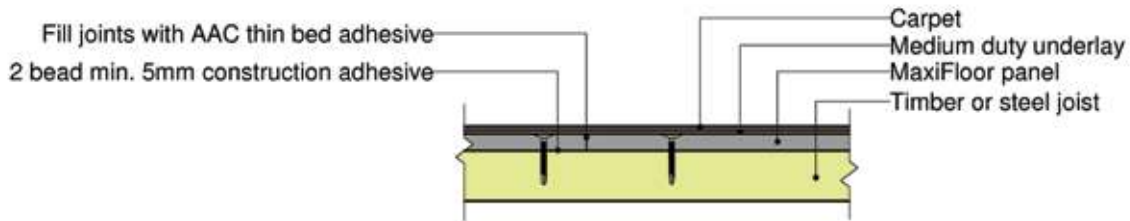

### 2.a MaxiFloor AAC Panel With Timber Floor

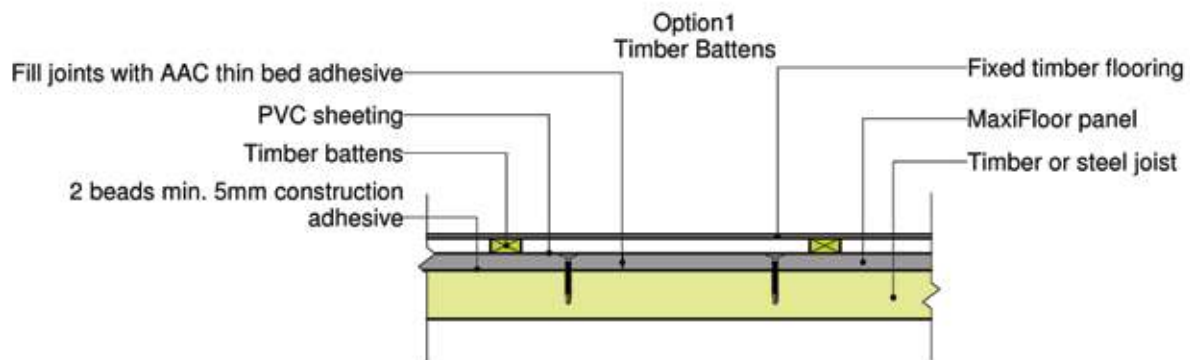

### 2.b MaxiFloor With Timber Floor

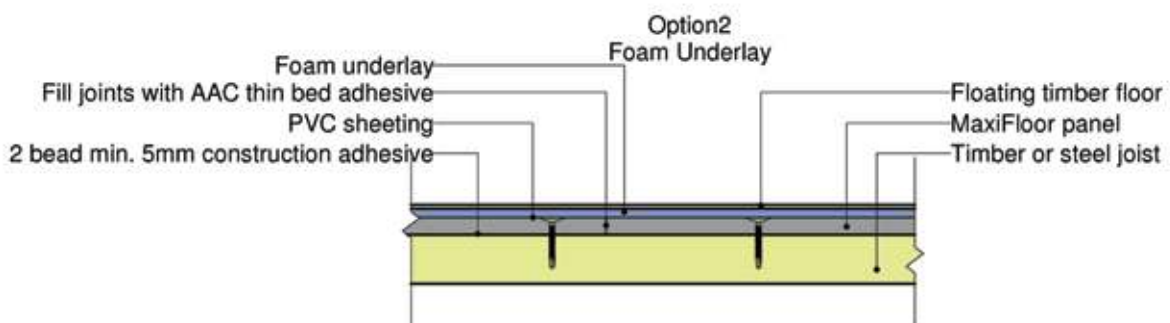

### 3. MaxiFloor AAC Panel With Tiles

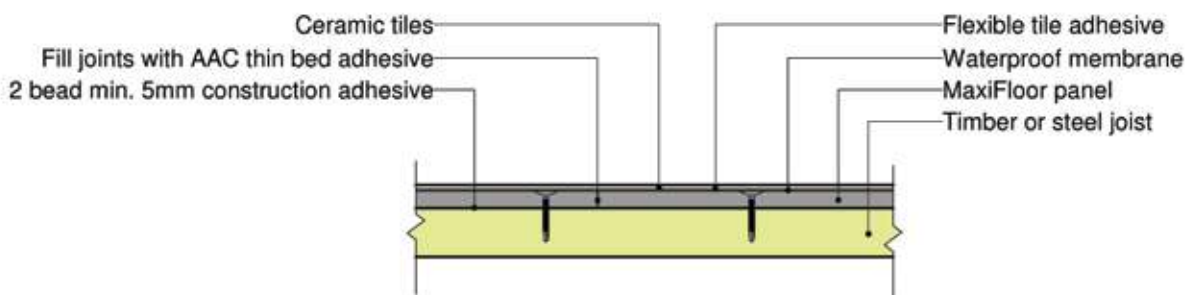

**4. MaxiFloor AAC Panel With Tiles on Cement Mortar Topping**

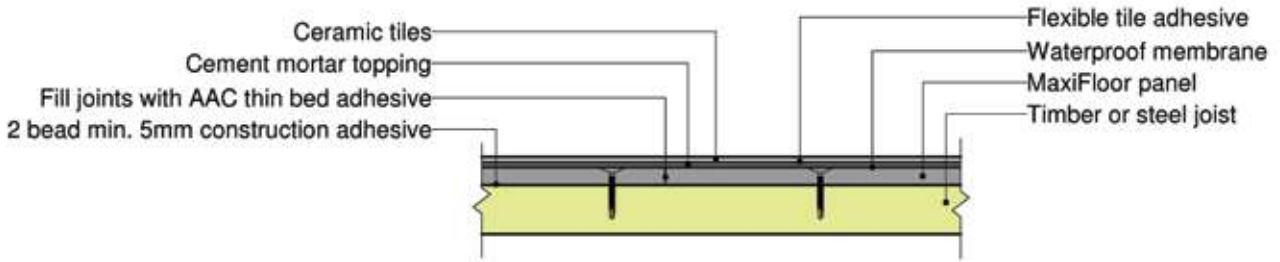

**5. MaxiFloor AAC Panel Fixing Arrangement**

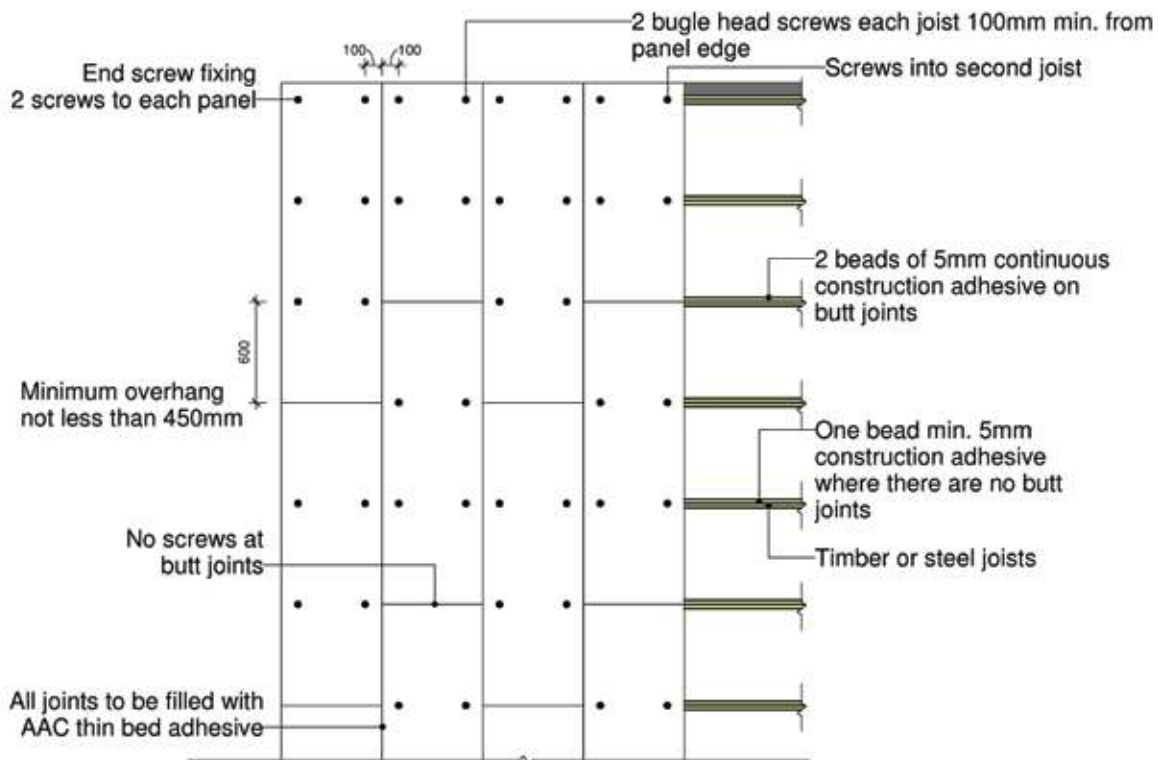

- Fill any recesses and chipping prior to any floor covering
- Refer Table 1 for screw sizing

**6. MaxiFloor AAC Panel Fixing Detail**

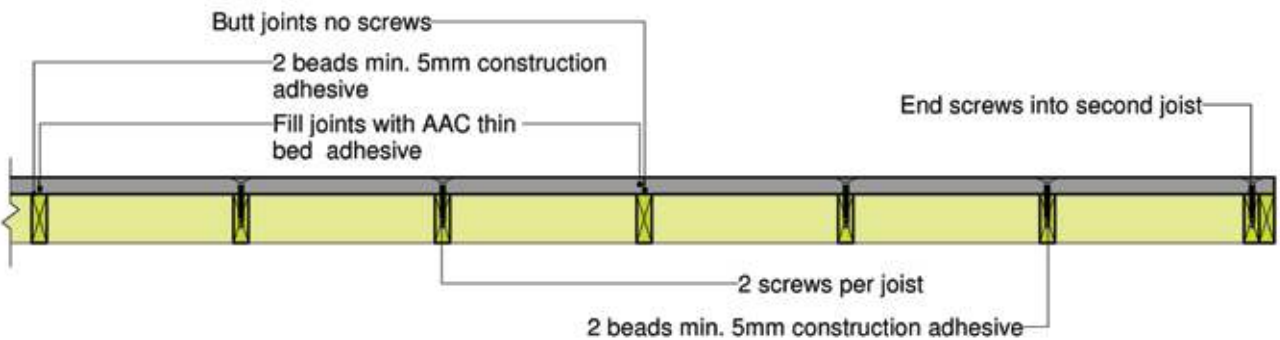



## 7. MaxiFloor AAC Panel Fixing Details

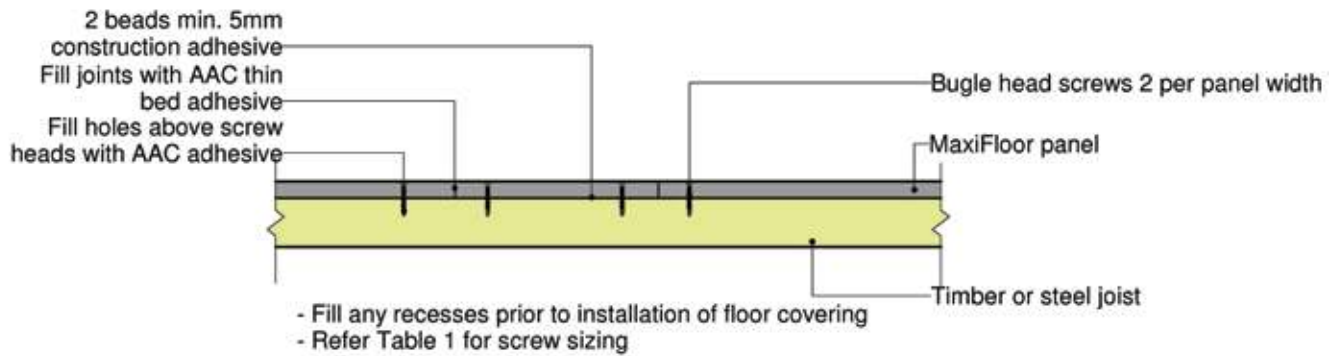

## 8. MaxiFloor AAC Panel With MaxiWall 50mm AAC Panel

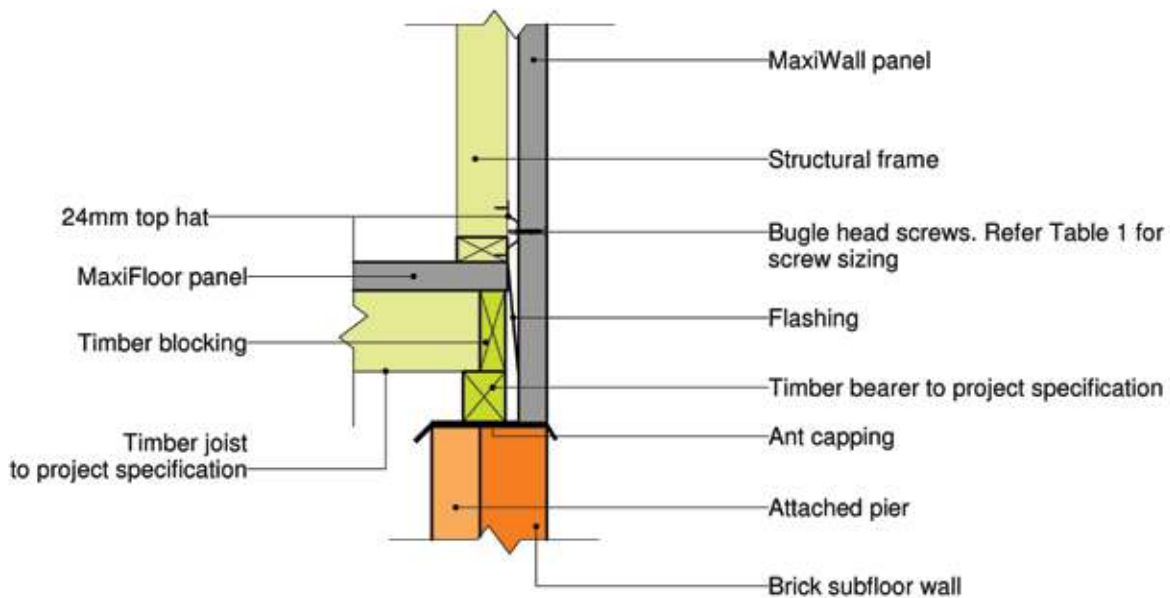

## 9. MaxiFloor AAC Panels With Platform Flooring

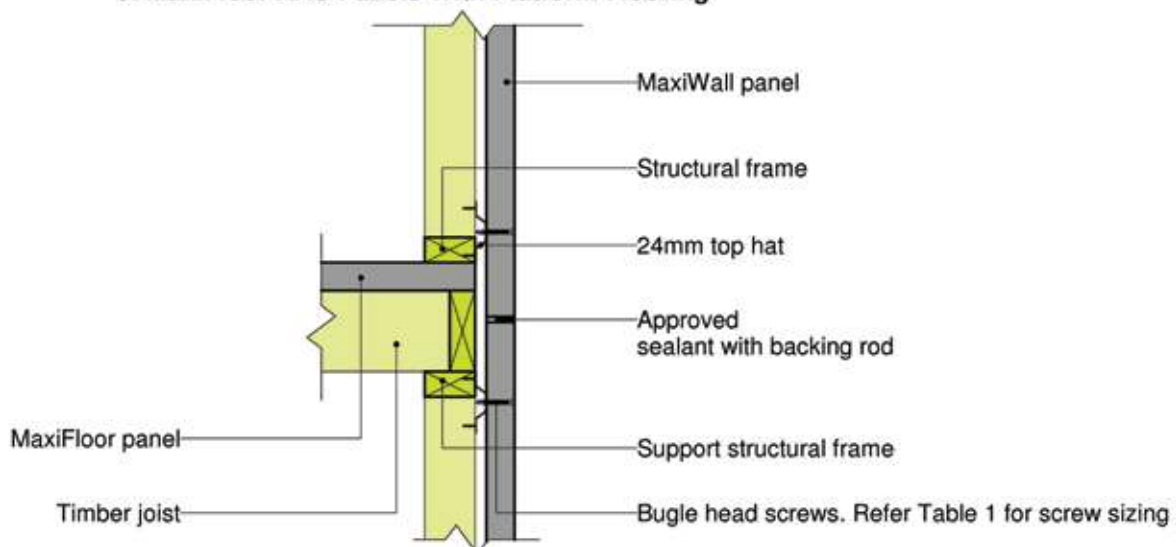

**10. MaxiFloor ACC Flooring Panels - Position Of Control Joints - Option 1**

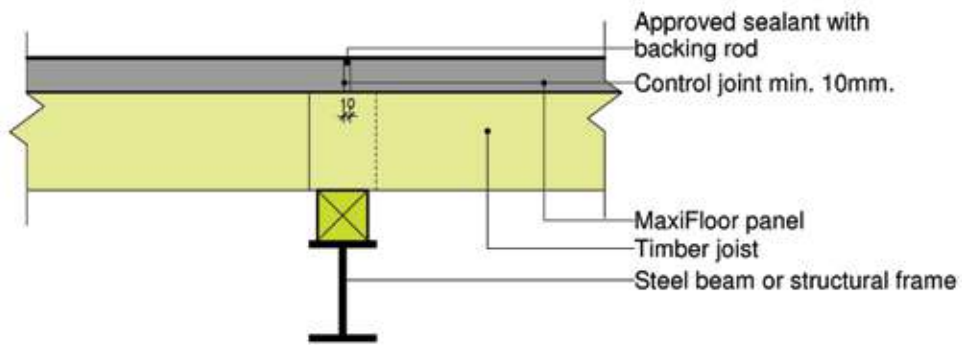

**11. MaxiFloor ACC Position Of Control Joints – Option 2 And 3**

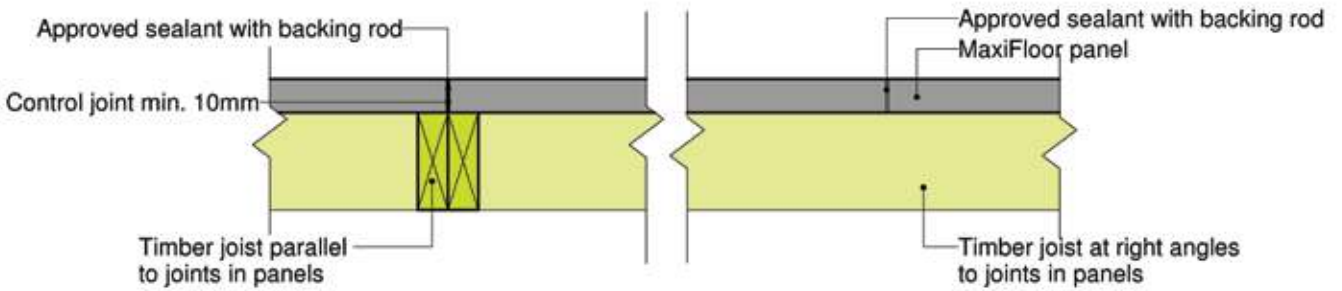

**12. MaxiFloor ACC MaxiFloor Screw Heads 50mm AAC Flooring Panel On Timber Joists**

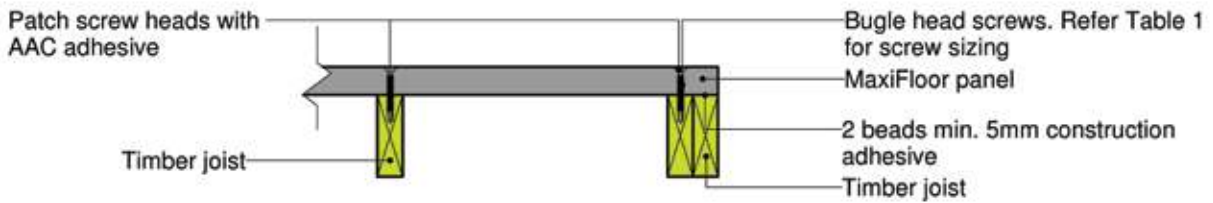

**13. MaxiFloor ACC Support Under Load Bearing Wall That Is At Right Angles To The Joists**

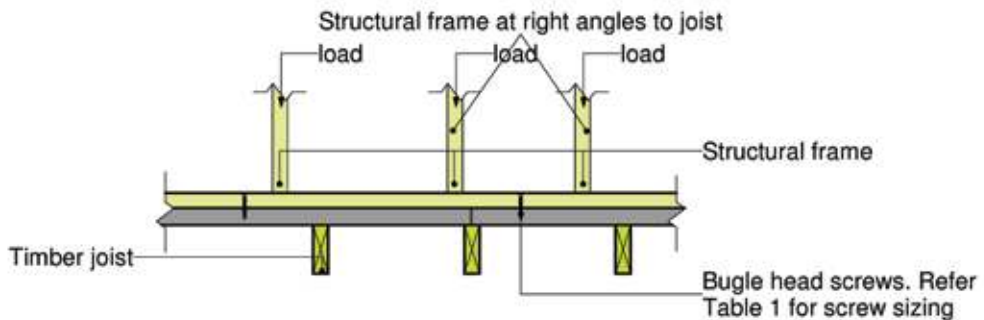

Max 50mm offset, otherwise blocking is to be provided

**14. MaxiFloor ACC Support Under Load Bearing Wall That Is Parallel To The Joists**

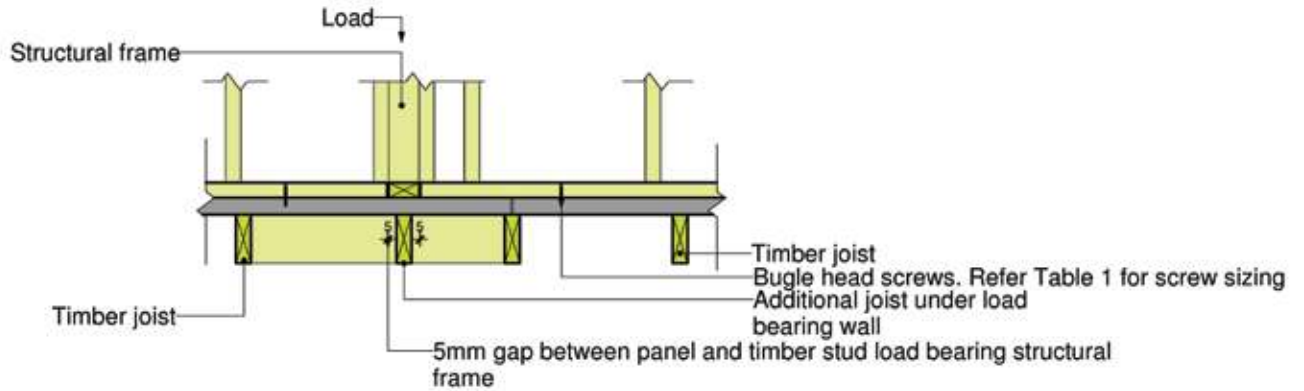

**15. MaxiFloor ACC Fitted And Platform Flooring**

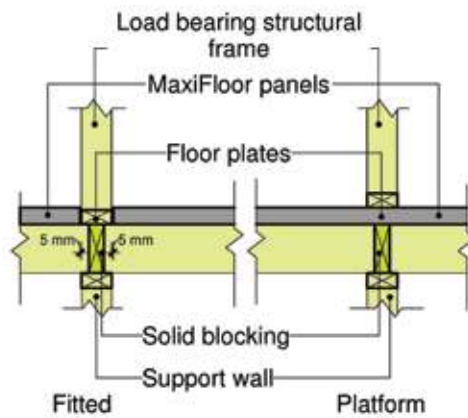

**16. MaxiFloor ACC Bolt Bracing Where Required Refer Engineer**

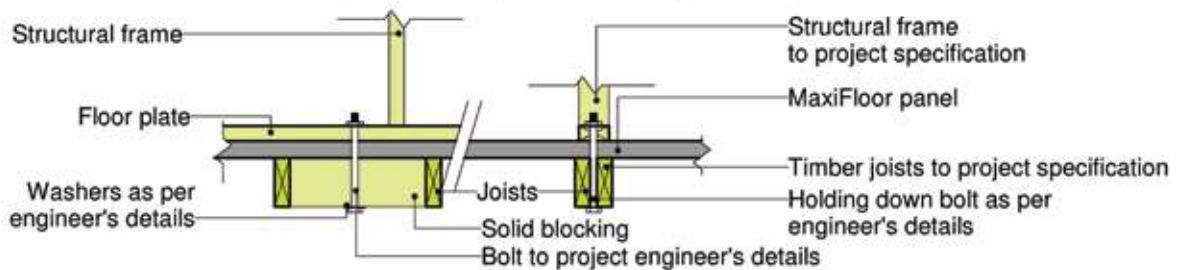

- Important: For hold-down connections other than bolts ensure the minimum requirements for embedment into timber is maintained. Refer to AS 1684.2 for hold-down for connection requirements.

**17. MaxiFloor ACC Penetration Detail**

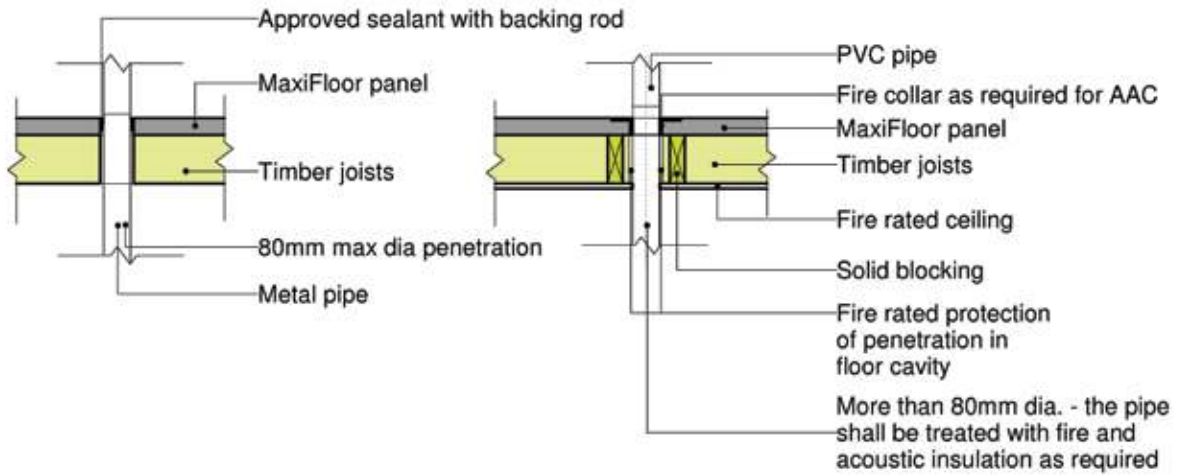

**18. MaxiFloor ACC Notching Detail**

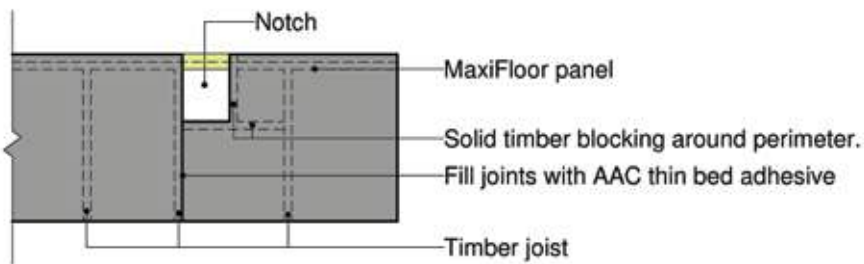



## 10.0 System Properties

### 10.1 Durability & Maintenance

Autoclaved aerated concrete has high porosity and relatively low alkalinity compared to traditional concrete. As a cement-based material, AAC resists water, rot, mold and mildew and can be precisely shaped and cut to tight tolerances when used in building construction.

MaxiFloor panels are embedded with steel mesh that is coated with corrosion resistant paint applied in a two-dip coating process. If panels are cut, apply anti-corrosion paint on the exposed steel. In typical applications, the completed floor system is protected from moisture ingress by moisture proof sealed joints.

Where there is significant and prolonged exposure to moisture, a waterproof tanking membrane must be applied to the panel surface. For durability in buildings refer to ABCB Handbook 2015.

### 10.2 Fire Resistance

MaxiFloor panels comes with CodeMark Certificate of Conformity and/or with compliance to the nominated performance requirements of AS 5146 and NCC, where relevant when installed with a fire rated ceiling system below. To achieve a floor FRL of (60)/60/60 for MaxiFloor system (using 50mm panel), the floor structural element is to be shielded from the lower compartment by 1 layer of 13mm and 1 layer of 16mm fire grade plasterboard or as specified by a plasterboard manufacturer.

To achieve a floor FRL of (90)/90/90, the floor structural element is to be shielded from the lower compartment by 2 layers of 16mm fire grade plasterboard or as specified by a plasterboard manufacturer.

MaxiFloor system (using 75mm panel) when specified and installed in accordance with AS 5146 Part 1, Part 2 and Part 3 shall satisfy the following NCC performance requirements for construction in bushfire prone areas up to and including BAL-FZ.

- Volume One – GP5.1
- Volume Two – P2.3.4

When constructed in accordance with AS 5146.3 and the relevant parts of AS 3959, MaxiFloor panels installed on balconies and verandahs (Attached structures – AS 3959 Section 3.2.1) are suitable for use in bushfire prone areas up to and including BAL-FZ. The following additional conditions must be adhered to:

- a. Support and fixings must comply with AS 5146 Part 3 – 3.4 and Section 6.
- b. Gaps exceeding 3 mm are not permitted.
- c. Vents and weep holes in sub-floor walls must be screened with corrosion resistant steel or bronze mesh of maximum 2 mm aperture.
- d. Sealants used in control joints and close to any construction gap shall be flexible external grade fire-rated polyurethane applied in accordance with manufacturer's specification.
- e. Floor linings, coverings or finishes applied to external floors must not contribute to the risk of fire.

### 10.3 Energy Efficiency

The MaxiFloor systems specified and installed in conjunction with this guide and AS 5146 Part 1, Part 2 and Part 3 where relevant may contribute to the thermal insulation performance of the building fabric in accordance with the NCC performance requirements in Volume One – JP1 and Volume Two – P2.6.1.

- The MaxiFloor 50mm panel has a thermal conductivity of:  $\lambda_{50\text{dry}} = 0.135 \text{ W/mK}$  and an element thermal resistance of R-Value  $0.370 \text{ m}^2\text{K/W}$ .
- The MaxiFloor 75mm panel has a thermal conductivity of:  $\lambda_{50\text{dry}} = 0.135 \text{ W/mK}$  and an element thermal resistance of R-Value  $0.555 \text{ m}^2\text{K/W}$ .

The element R-Value is used in floor system R-Value calculations that include air-films, cavities added insulation and other elements such that the minimum total R-Value for a floor system exceeds the minimum specified Deemed-to-Satisfy Total R-Value for a specified Climate Zone. These values are provided in NCC Volume One – Table J1.6 and NCC Volume Two – Table 3.12.1.4. The designer should use the above data to demonstrate project compliance.

### 10.4 Sound Transmission

The acoustic performance of a single leaf 75mm thick AAC panel tested in accordance with AS 1191 and AS/NZS ISO 717.1 is  $R_w (C; C_{tr}) = 34 (-2; -3)$ . Section 6 in AS 5146 Part 3 provides acoustic performance figures of MaxiFloor 75mm with various floor coverings. These figures include options that meet the Deemed-to-Satisfy requirements for the performance requirement of separating floor under Volume One – F5.4.

Additionally, the following option is available as part of the Deemed-to-Satisfy Provisions in NCC Volume One Specification FS-2-2 Table 3 which attains  $R_w + C_{tr} \geq 50$  and  $L_{n,w} \geq 62$ :

- 75mm thick autoclaved aerated concrete floor panel with:
  - › 8 mm ceramic tiles with flexible adhesive and waterproof membrane located above the slab; and
  - › Timber joists at 600 mm centres; and  $\geq R1.5$  glass wool insulation positioned between timber joists; and
  - › 28 mm metal furring channels and resilient mounts fixed to underside of joists; and
  - › Two layers of 13 mm plasterboard fixed to furring channels.

Where the floor system requires specific acoustic performance such as local council regulations or for a particular floor purpose, engaging a specialist acoustic consultant for such projects for design advice and installation detail is recommended.

### 10.5 Waterproofing

BCA Volume One Part FP1 is satisfied when the floor system is detailed and installed in accordance with AS 5146 Part 3 – Section 6.

NCC Volume Two BP2.2.2 is satisfied when the residential external floor system is detailed and installed in accordance with AS 5146 Part 3 – Section 6.

## 11.0 Material Handling

### 11.1 Panel Unloading

MaxiFloor panels are shipped in packs of 9 to 20 depending on its thickness and stacked flat or on edge. The packs are strapped to strengthened timber pallets and wrapped in resilient plastic sheeting. Crane slings and forklifts may be used in accordance with standard industry practice.

The Project Engineer is cautioned regarding the initial delivery of the panel packs as it should be unloaded as close as possible to the installation site. Secondary handling of the panels increases the risk of damage, and installation of damaged panels may void the warranty.

### 11.2 Storage & Protection

MaxiFloor panel packs, when on construction sites must be stored on a flat-grade level that is not prone to standing water, erosion or settling. It must be left on its edge to avoid sagging. The packs may be stacked up to 3 packs high on flat load-bearing stable platforms so far as is reasonably practical and safe for workers and others. The packs should not be stacked if stored on un-level and natural ground.

MaxiFloor panels should ideally be kept dry with attention paid to protecting panel ends, edges and surfaces. In adverse weather conditions the panels must be kept covered. Do not “shakeout” stored panels until they are ready to be installed.

MaxiFloor panels with a central single layer of reinforcement and length over 1800mm are at risk of cracking under their self-weight when carried or lifted from the horizontal or tilted from the vertical position. Adequate support must be provided when lifting. Panels must always be carried edge up. Lifting equipment must be used when necessary.

Most chipped corners and edges can be repaired with MaxiFloor’s approved patching compounds. If reinforcing steel mesh is visible it must be protected using the approved anticorrosion paint. Panels that have surface or minor cracks are usable but if not sure contact an authorized Big River Group’s representative.

### 11.3 Health & Safety Safety

Data Sheets (SDS) are provided with all MaxiFloor panels including major components associated with the system such as coatings, patching compound, thin-bed adhesive and reinforcement touch-up paint.

AAC building products contain Crystalline Silica (Quartz) that as dust is produced during cutting, grinding or drilling. It is categorized as a health hazard when inhaled. Approved dust masks and protective safety glasses or goggles must be worn for dust generating operations.

All AAC products are to be handled and worked on-site with the appropriate protective clothing. Protective gloves must be used for all construction operations. It is the responsibility of the builder/site supervisor to ensure that installation contractors adhere to safe work practices and suitable clothing.

## 12.0 Material Property

**Table 7. Physical Property and Structural Design Capacity**

Property	Value	Unit
Declared Mean Dry Density $P_{m,g}$	525	kg/m <sup>3</sup>
Characteristic Compressive Strength $f_{ck}$	3.0	MPa
Characteristic Flexural Strength $f_{cflk}$	0.54	MPa
Declared characteristic bending capacity $\phi M_k$ kNm/m width of floor 50mm	0.2	kNm
Declared characteristic bending capacity $\phi M_k$ kNm/m width of floor 75mm	0.2	kNm

## 13.0 Standard and Compliance

No.	Standard Compliance	Description
1.	NCC Vol. One: BP1.1, BP1.2	Nominated fixing method and support spacing for permanent and imposed actions
2.	NCC Vol. Two: P2.1.1	Structural stability and resistance to permanent and imposed actions
3.	NCC Vol. One: CP1, CP2, GP5.1	Fire resistance level for floor system
4.	NCC Vol. Two: P2.3.1, P2.3.4	Fire resistance level for floor system
5.	NCC Vol. One: Part FP1	Weatherproofing for external floor system
6.	NCC Vol. Two: BP2.2.2	Weatherproofing for external floor system
7.	NCC Vol. One: JP1	Energy efficiency performance requirements
8.	NCC Vol. One: FP5.4	Sound transmission and insulation
9.	NCC Vol. Two: P2.6.1	Energy efficiency performance requirements
10.	NCC Vol. One: A2.2(a), (v)	Thermal conductivity and resistance
11.	NCC Vol. Two: 1.2.2(a), (iii)	Thermal conductivity and resistance
12.	AS/NZS ISO 717.1	Rating of sound insulation in buildings and of building elements – Part 1: Airborne sound transmission
13.	AS/NZS 1170.0	Structural design actions – Part 0: General principles
14.	AS/NZS 1170.1	Structural design actions – Part 1: Permanent, imposed and other actions
15.	AS 1191	Method for laboratory measurement of airborne sound transmission insulation of building elements
16.	AS 1530.4	Fire resistance test of elements of construction
17.	AS 1684	Residential timber – framed construction
18.	AS 1720	Timber structures
19.	AS 2870	Residential slabs and footings
20.	AS/NZS 2904	Damp-proof courses and flashing
21.	AS 3660.1	Termite Management – Part 1: New building work
22.	AS 3740	Waterproofing of domestic wet areas
23.	AS 3959	Construction of buildings in bushfire-prone areas
24.	AS/NZS 4200 Part 1, Part 2 & Part 3	Installation of pliable building membranes
25.	AS 5146 Part 1	Reinforced aerated concrete
26.	AS/NZS 4600	Cold-formed steel structures
27.	AS 4654 Part 1 & Part 2	External waterproofing membrane systems
28.	AS 5146 Part 1, Part 2 & Part 3	Reinforced aerated concrete – Part 1: Structure, Part 2: Design, Part 3: Construction
29.	NASH Standard	Residential and low-rise steel framing



## 14.0 Responsibility and Warranty

### 14.1 Responsibility

The final specification and certification of the floor system using MaxiFloor 50 mm and 75 mm AAC panels lie solely with the qualified design and building construction professionals responsible for the project. These professionals would generally comprise of structural engineers, fire engineers and acoustic engineers. The design consideration, fixing specifications and installation details in this manual represent common types of construction and detailing practice used in Australia. A competent professional must approve any variations or alternatives to the design and installation details described in this manual.

### 14.2 Warranty

MaxiFloor panels are manufactured to international quality standards. Warranty statement for the panels is available on Big River Group's website: [www.bigrivergroup.com.au](http://www.bigrivergroup.com.au). Big River Group warrants that its panels are free from defects in materials and manufacture subject to the conditions and exclusions set out in the Product Warranty.

### Disclaimer

The information contained in this Installation Guide is only advisory and general in nature. It is not intended to substitute advice or consultation from registered building construction professionals to ensure designs, systems and installation for projects conform to the National Construction Code and Building Codes of Australia including any other laws imposed by the States or local councils. The user of this manual understands and agrees that Big River Group Pty Ltd, its member companies, its officers, supplier, agents and employees shall not be liable in any manner under any theory of liability for the user's reliance on this manual. The user agrees to release, hold harmless and indemnify Big River Group, its member companies, successors, assigns, officers, supplier, agents and employees from any and all claims of liability, costs, fees (including lawyer's fees), or damages arising in any way out of the use of this information. If you have any questions, please visit [www.bigrivergroup.com.au](http://www.bigrivergroup.com.au) or call us on 1300 88 1958.

## Contact Us

For all sales and technical enquiries please contact the experts at Big River:

**Phone:** 1300 881 958

**Email:** [info@bigrivergroup.com.au](mailto:info@bigrivergroup.com.au)

For all technical enquiries please contact:

**Phone TECHSERV:** 02 9630 5288

For your nearest Big River branch or to download information:

**Visit:** [www.bigrivergroup.com.au](http://www.bigrivergroup.com.au)

**BigRiver**

Building Australia for over 100 years

Big River Group Pty Ltd  
ABN 72 000 009 754  
July 2018

